

# Installation Diagram

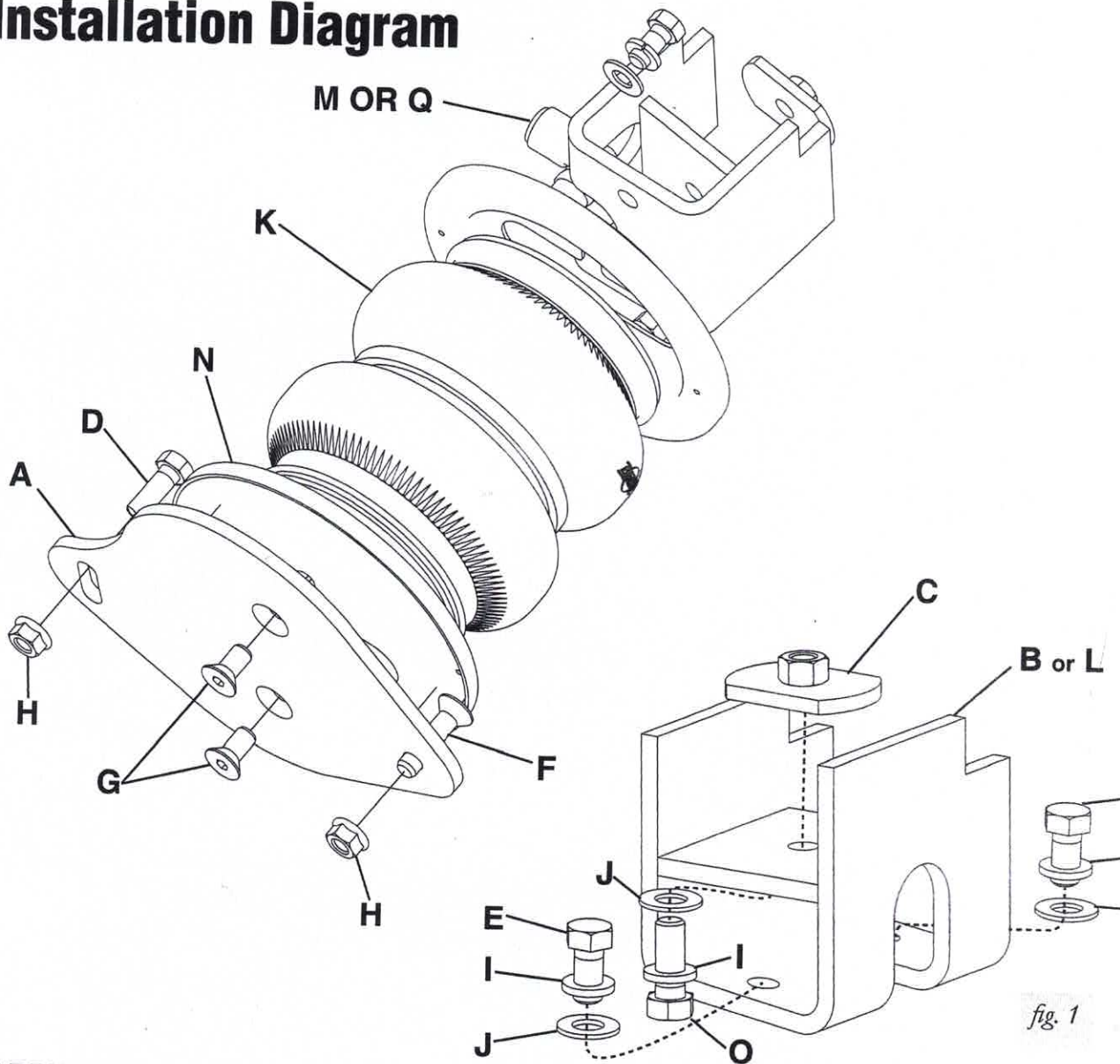

## HARDWARE LIST

Item	Part #	Description.....	Qty
A	03614	Rear bottom plate.....	2
B	07325	Upper bracket ASM - left rear.....	1
C	10814	Clamp plate.....	2
D	17107	3/8"-16 x 1 Hex bolt.....	2
E	17203	3/8"-24 x 3/4 Hex bolt.....	4
F	17206	3/8"-16 x 1.5 Countersink cap screw ..	2
G	17215	3/8"-24 x 3/4 Countersink cap screw ..	4
H	18422	3/8" Flange nut.....	4
I	18427	3/8" Lock washer.....	8
J	18444	3/8" Flat washer.....	8
K	58449	2B6 Air bag w/ 3/8" Zytel.....	2
L	07416	Upper bracket ASM - right rear.....	1
M	21846	Fitting 3/8MNPT.....	2
N	11801	Roll plate.....	4
O	17188	3/16"-16 x 1.25 Hex Bolt.....	2
P	18544	.25" Spacer (not shown).....	2
Q	21867	Fitting 1/4MNPT.....	2

## TOOLS LIST

Description.....	Qty
Jack.....	1
Jack Stands.....	2
1/2" Drive Ratchet.....	1
3/8" Drive Ratchet.....	1
15mm Socket.....	1
16mm Socket.....	1
18mm Socket.....	1
9/16" Standard Socket.....	1
7/32" Allen Wrench.....	1
9/16" Wrench.....	1
18mm Wrench.....	1
15mm Wrench.....	1
Coil Compressor Tool.....	1
3/8" x 4" Extension.....	1

## PREPARING REAR BAG ASSEMBLY

### NOTE

Refer to fig. 1 on page 3 for detailed assembly.

1. Install supplied air fitting (M) into air bag assembly before attaching the upper bracket. Seal with teflon tape or thread sealant.

### NOTE

Determine where the air line will run. When running 1/4" line, the fitting can face inboard at the bracket to protect the connection.

2. Insert the 3/8" - 16 x 1 1/2" countersink cap screw into the lower mounting plate before installing the bag assembly.
3. Apply the roll plates (N) to the top and bottom of the air spring assembly. Orient as shown in fig. 5.
4. Attach lower mounting plate using supplied 3/8"-24 x 3/4" countersink cap screw. Torque to 27 Nm (20 ft/lbs)
5. Using supplied 3/8"-24 x 3/4" hex bolts, lock washers, and flat washers, attach the upper bracket assembly. The upper bracket window/air port faces toward the outside of the vehicle. Torque the bolts to 27 Nm (20 ft/lbs).

## INSTALLING BAG ASSEMBLY

### NOTE

Driver's side installation shown.

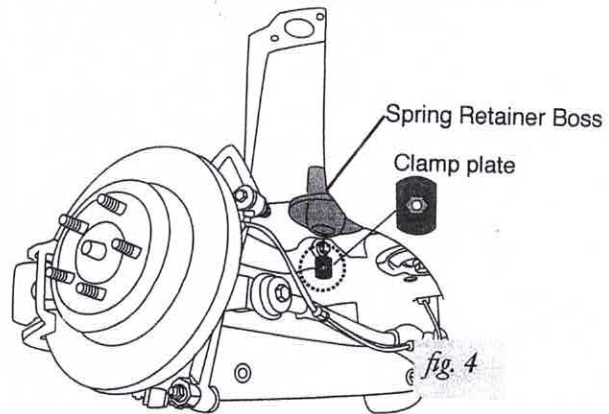

1. Insert clamp plate into spring retainer boss with the nut facing upward (fig. 4).
2. Collapse assembly and slide into stock coil spring location.

